

ITEM	QTY	DESCRIPTION	MATERIAL
1	1	INSULATOR BOBBIN	REINFORCED GLASS POLYESTER
2	2	M10 x 16 SET SCREW	304 STAINLESS STEEL
3	2	M10 FLAT WASHER	304 STAINLESS STEEL

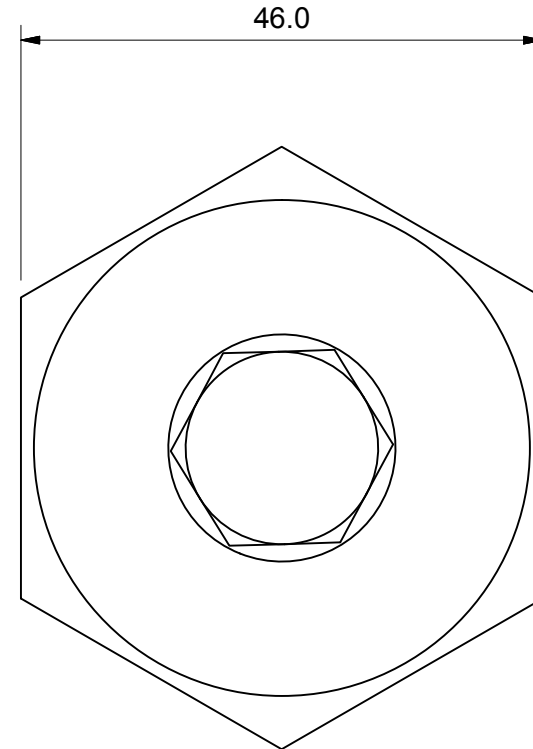
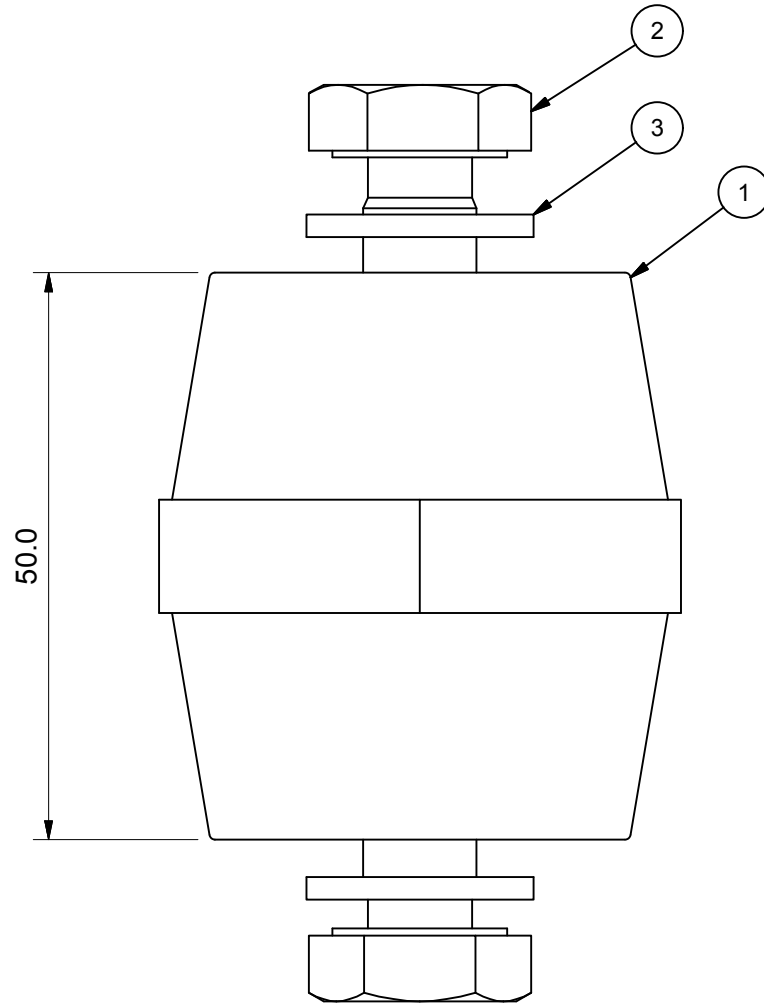

**LPI**<sup>®</sup>  
WWW.LPI.COM.AU

TOLERANCES  
UNLESS OTHERWISE STATED  
X. ± 1.0  
X.X ± 0.5  
X.XX ± 0.25

LIGHTNING PROTECTION INTERNATIONAL PTY. LTD.  
A.B.N. 11 099 190 897  
49 PATRIARCH DRIVE  
HUNTINGFIELD TAS 7055, AUSTRALIA  
PH: +61 3 6227 1955 FX: +61 3 6229 1900  
© 2015 LIGHTNING PROTECTION INTERNATIONAL PTY. LTD.

TITLE: LPI® M10 EARTH BAR INSULATOR	
PRODUCT CODE EB-INSU-OPT-M10	REV 1
SCALE NTS	SHEET 1 OF 1 A4
FILE EB-INSU-OPT-M10.E.idw	DATE 24/09/15