

REV.	DESCRIPTION	DATE	CHKD	APPD	ITEMS LIST			
					ITEM No.	QTY.	DESCRIPTION	MATERIAL
					1	1	INTERMEDIATE ROD PLATE	UNS C84400 HIGH STRENGTH COPPER ALLOY
					2	1	KEEPER PLATE	UNS C84400 HIGH STRENGTH COPPER ALLOY
					3	-	-	-
					4	1	M10 U-BOLT	316 STAINLESS STEEL
					5	2	M10 NUT	316 STAINLESS STEEL
					6	2	M10 FLAT WASHER	316 STAINLESS STEEL
					7	2	M10 SPRING WASHER	316 STAINLESS STEEL

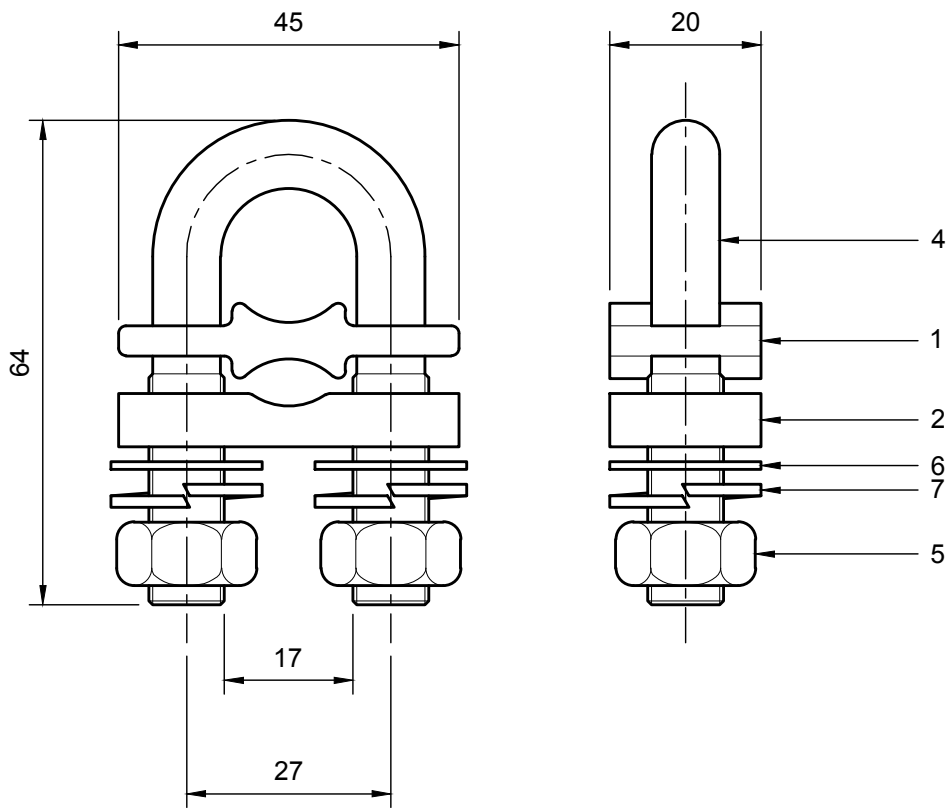

**LIGHTNING PROTECTION INTERNATIONAL**  
 49 PATRIARCH DRIVE, HUNTINGFIELD TASMANIA 7055  
 Ph: +61 3 6281 2475 Fax: +61 3 6229 1900  
 www.lpi.com.au

© NO PART OF THIS DRAWING MAY BE REPRODUCED, STORED  
 IN A RETRIEVAL SYSTEM IN ANY FORM OR TRANSMITTED BY  
 ANY MEANS WITHOUT THE PRIOR PERMISSION OF  
 LIGHTNING PROTECTION INTERNATIONAL PTY. LTD.

CLIENT		VARIOUS	
LIGHTNING PROTECTION INTERNATIONAL U-BOLT CLAMP UBRC35120 ASSEMBLY			SCALE 1:1
DRG. No. LPI – UBRC35120		SHT. 001	A4 REVISION 0
DRAWN MC	CHECKED G. TURVEY	APPROVED M. AUSTIN	
DESIGNED GT	DATE 03-03-2014	DATE 03-03-2014	

LPI-UBC-002

Rev. 0